

NOTE: All materials compliant with RoHS, REACH and PrO65 standards

REV.	DATE	ECN NO.	DESCRIPTION
A0	2021. 04. 17	/	/

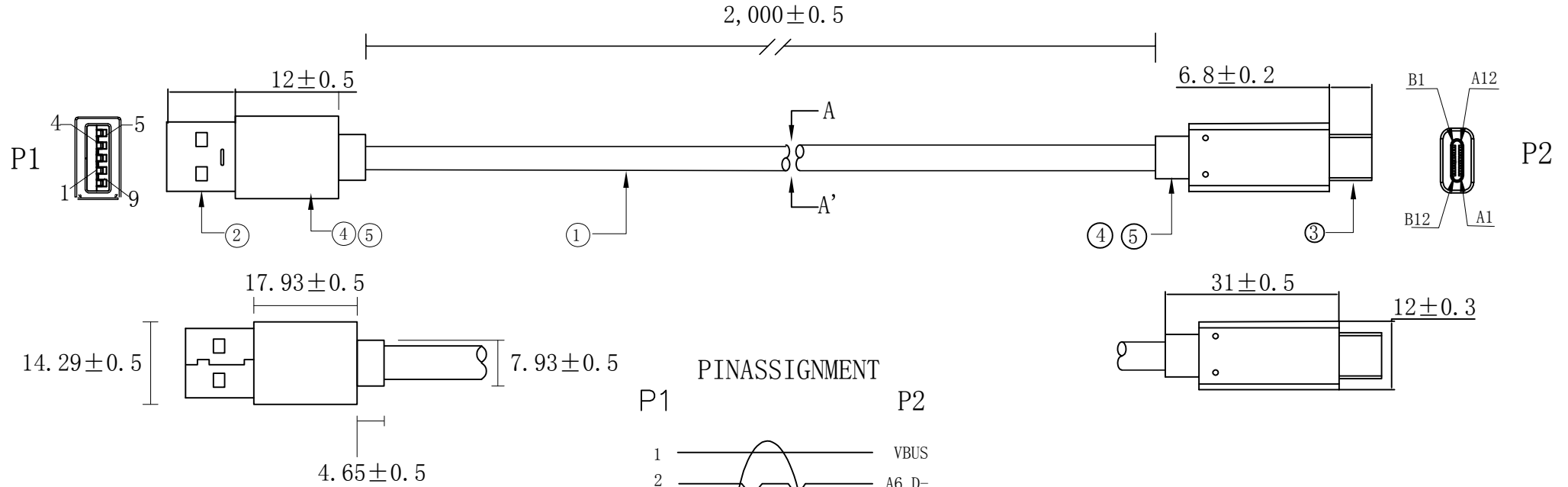

PIN ASSIGNMENT

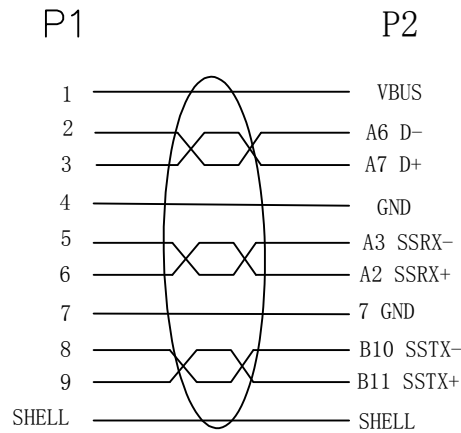

Testing Requirements:

- 100% real machine screen test
- Insulation resistance: 10MΩ MIN (300DC/0.01s).
- Conduction impedance: 2Ω MAX.

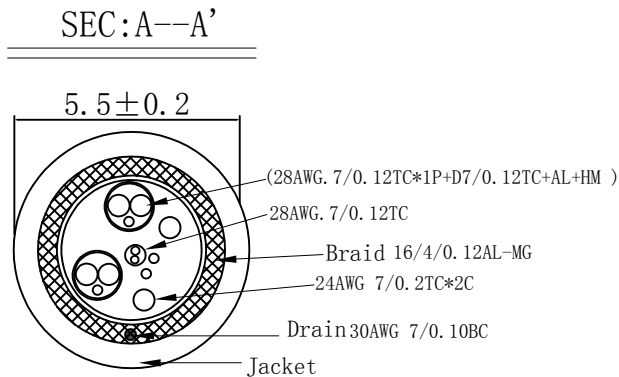

NO.	NAME	SPECIFICATIONS	Q' TY	UNIT
5	OUTER MOLDING	Black PVC 40P	10	G
4	INNER MOLDING	MG70 LDPE	10	G
3	CONNECTOR	USB3.0 TYPE C/M connector black core/nickel plated iron case/pin gold plated	1	PCS
2	CONNECTOR	USB3.0A /M connector blue core/nickel plated iron case/pin gold plated	1	PCS
1	CABLE	USB3.0 (28AWG. 7/0. 12TC*1P+D7/0. 12TC+AL+HM )*2+(28AWG. 7/0. 12TC)*1P+24AWG 7/0. 2TC*2C+ADB+PVC OD:5.5MM BLACK 2,000 ±0.5mm	AR	MM

	MODEL #:	USB3-AC2MB
	PAGE:	1 / 1
DRAW:	NOTES:	
DATE:	SCALE:	1mm = 1mm
UNIT: mm	TOLERANCE:	+/- 0.15 mm
SITE: coolgear.com	CONTACT:	support@coolgear.com

F  
E  
D  
C  
B  
A

8 7 6 5 4 3 2 1